

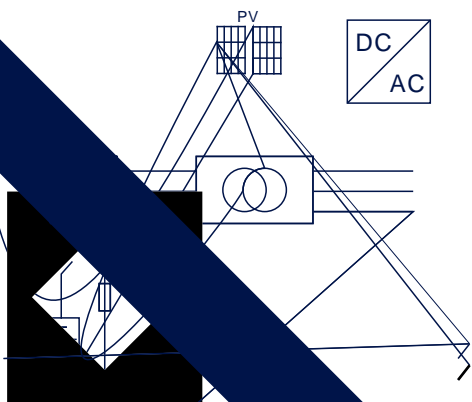

Smart C&I BESS + Solar PV System

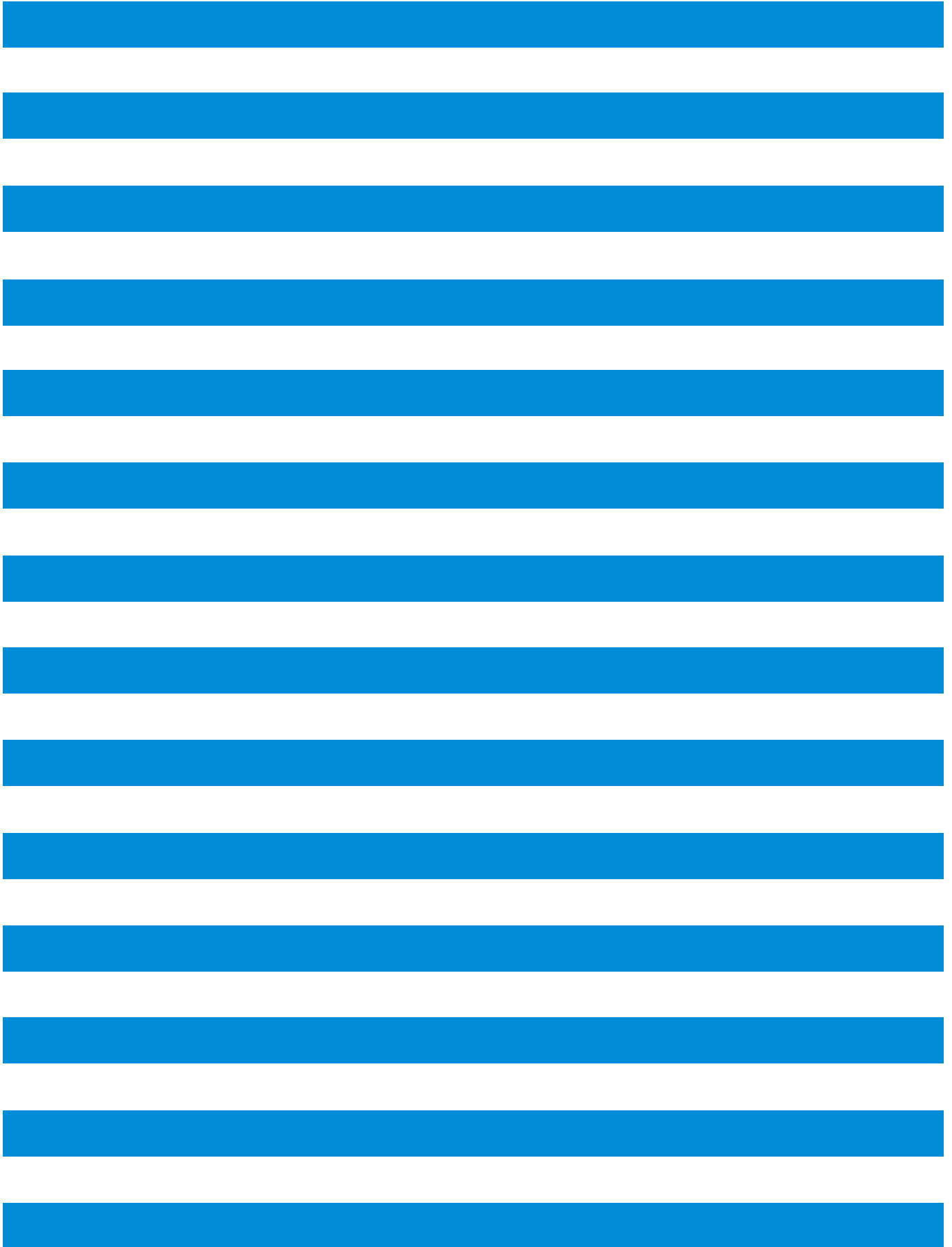

All-in-one design, integrated battery pack, battery management system BMS, energy management system EMS, modular PCS and fire protection system in one. The system is equipped with transformers and switchgear. The system can be combined with photovoltaic power generation to form a grid-tied solar with energy storage system. Multiple systems can be connected in parallel for flexible expansion. The system is suitable for a variety of applications such as, on-grid/off-grid solar energy and storage system, backup power supply, and solar-diesel-microgrid system.



[Redacted]

[Redacted]

[Redacted]

[Redacted]

[Redacted]

[Redacted]

[Redacted]

[Redacted]

[Redacted]

[Redacted]

[Redacted]

NO.	Name	Recommended model/ Specifications	QT Y	Remark
1	Energy Storage System Cabin	100kW/215kWh	-	See NO. 1.1 to 1.3 for details
1.1	Li-ion Battery	Adopting LFP battery, continuous charging/discharging multiplication rate 0.3C, including battery module, switch box, BMS system, etc.	1	
1.2	PCS	Rated power 100kW, output voltage AC400V, three-phase three-wire.	1	
1.3	Cabin	L*W*H: 1414*1500*2542mm, including temperature control system, fire protection system, power distribution system, heat dissipation duct and connecting cables between equipment in the box, IP66	1	
2	Transformer & Switch Cabin	Grid-connected voltage 220V	-	See NO. 2.1 to 2.3 for details
2.1	Transformer	Dry SCB12-125kVA-0.4/0.22kV Dyn11, rated capacity 125kVA		
2.2	400V Switch Cabin	220V, 315A	1	
2.3	Cabin	W*D*H: 1150 x 1900		

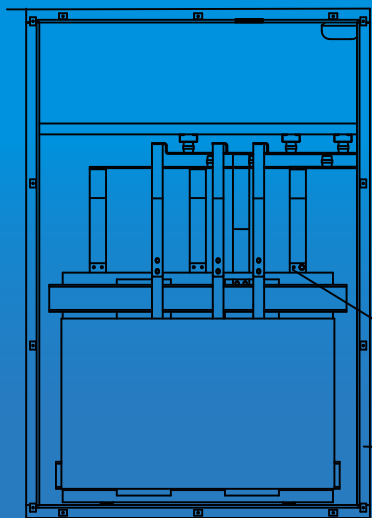

Grid-connected scenario

A grid-connected BESS offers the ability to capture and store electrical energy when the demand is low and provide electricity when the demand is high. This ability allows the business to operate more efficiently and sustainably.

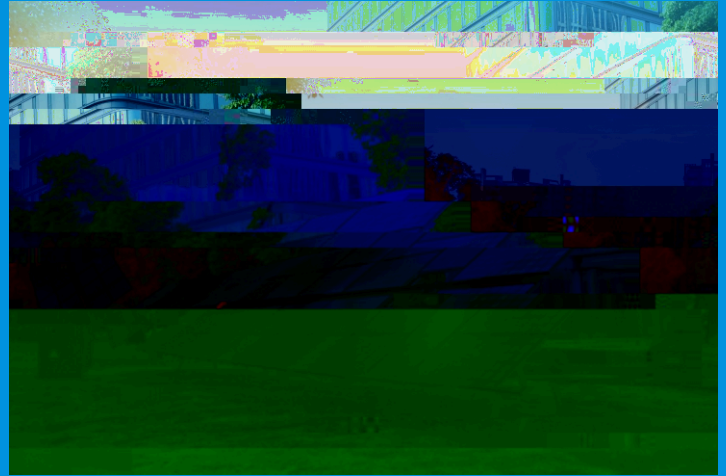
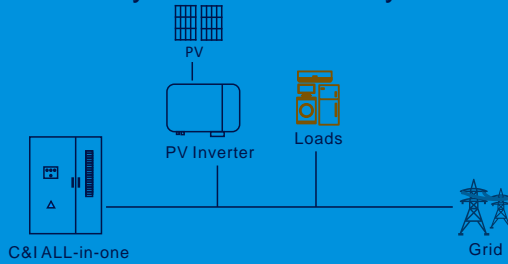

Parallel connection scenario

The BESS connected in parallel allows for easier scalability, additional BESS can be added or removed without affecting the existing system. With the parallel connection, the system is able to have more flexibility in terms of system design and operation.

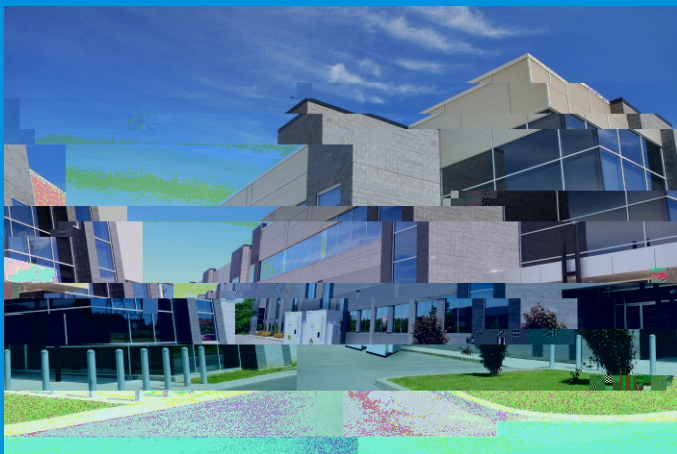
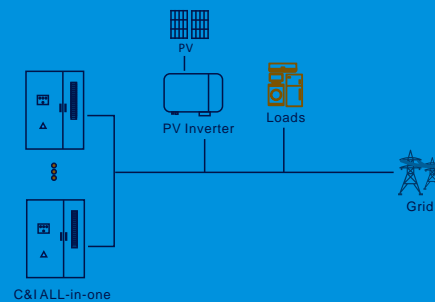

Microgrid scenario

Combining with solar or diesel generator, the system can become a local energy production and distribution network that can function independently when there is no access to grid.

